

EDGE 100

A clean finish every time - the EDGE 100 downlight features a wider trim for ease of install, especially when recessed into concrete ceilings. Utilising advanced LED engines to achieve unmatched illumination with a fraction of the energy.



FEATURES

- + Adjustable head up to 25°.
- + Precision reflector with clear lens – for better light distribution.
- + Specially designed heat sink – for class leading heat dissipation.
- + Deep set lamp position – for visual comfort and glare control.
- + Suitable for concrete install with concrete canister. (Ordered Separately).
- + Next-Generation LED chip technology.
- + Compatible with remote Casambi CBU-TED Bluetooth Controllable Dimmer (71-CASCBU) & with Casambi BasicDim Driver 13W (71-CAS350).



GENERAL SPECIFICATIONS

LED		10W	12W	15W
Lumens	(3000K)	960 lm	1105 lm	1270 lm
	(4000K)	1000 lm	1150 lm	1320 lm
Efficacy		Up to 95 lm/W		
Colour Temperature	3000K, Warm White			
	4000K, Cool White			
Material		Powder Coated Aluminium		
Finish		White Black		
Beam		15° 24° 36° 60°		
CRI		92+		
IP		44		
Colour Deviation		SDCM ≤2		
UGR		<19		
Lifetime		>55,000hrs L80 B10		
Warranty		7 Years		

Please Note: When using C-Bus, user universal or trailing edge dimming modules.

PROJECT DETAILS

PROJECT:

TYPE:

NOTES:

DIMENSIONS

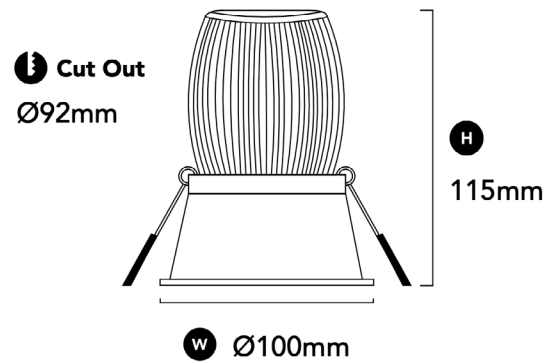

DRIVER SPECIFICATIONS

Dimensions	L 104 x W 43 x H 24 mm
Power	250mA 300mA 350mA 240V Remote Flicker Free Dimmable Driver
Dimming	Phase Cut Dimming
Power Factor	> 0.90

DALI Dimming Available Upon Request

PRODUCT CODES

White, 3000K	118-ED2L13W603
Black, 3000K	118-ED2L13B603
White, 4000K	118-ED2L13W604
Black, 4000K	118-ED2L13B604

REFLECTOR CODES

36° Reflector	118-RFLP36
24° Reflector	118-RFLP24
15° Reflector	118-RFLP15